

Test van for maintenance and diagnostics of power transformers



Transformer Test Van

- Routine and advanced diagnostic tests
- Centralized control and reporting
- Two sets of cables (HV&LV) are shared among different instruments
- Automated test circuit arrangement and switching process
- Safe operation and user guidance through the tests
- Easy extraction of mounted instruments for stand-alone use

Description Transformer Test Van

The Megger transformer test van is a vehicle equipped with a number of instruments for on-site condition assessment of power transformers. The biggest advantage of the van solution compared to separate or multi-functional instruments is its instantaneous readiness to test, quick proceeding to results and clean up at end of testing. All leads are on drums, pre-connected to instruments, through automatic switching no need to climb several times. This results in increased productivity, safety and user comfort, considering an air-conditioned office like work environment.

Commissioning testing and preventative maintenance checks are crucial and often prescribed for safe and uninterrupted operation of power transformers and substations. A combination of routine electric tests and advanced diagnostic techniques in accordance with international standards can be performed with a dedicated transformer test van.

Deterioration of electrical insulation may be identified with insulation tests (insulation resistance, power factor / dissipation factor and capacitance as well as dielectric frequency response measurements). Mechanical damage due to transport or through-fault current influence, malfunctions or winding shorts are typically found using frequency response analysis, leakage reactance, winding resistance measurement and on-load tap changer tests. Turns ratio, vector group, no-load and short-circuit loss assessments are feasible after repairs to guarantee the high quality of maintenance. Oil samples are routinely taken for dielectric strength measurements and dissolved gas analysis. To perform all these tests on-site one typically takes separate devices with their own test leads and other accessories. Often it becomes quite time consuming and challenging in terms of numerous tests schemes and climbs on top of the transformer. The latter could possibly also lead to accidents during tests.

Connection diagram

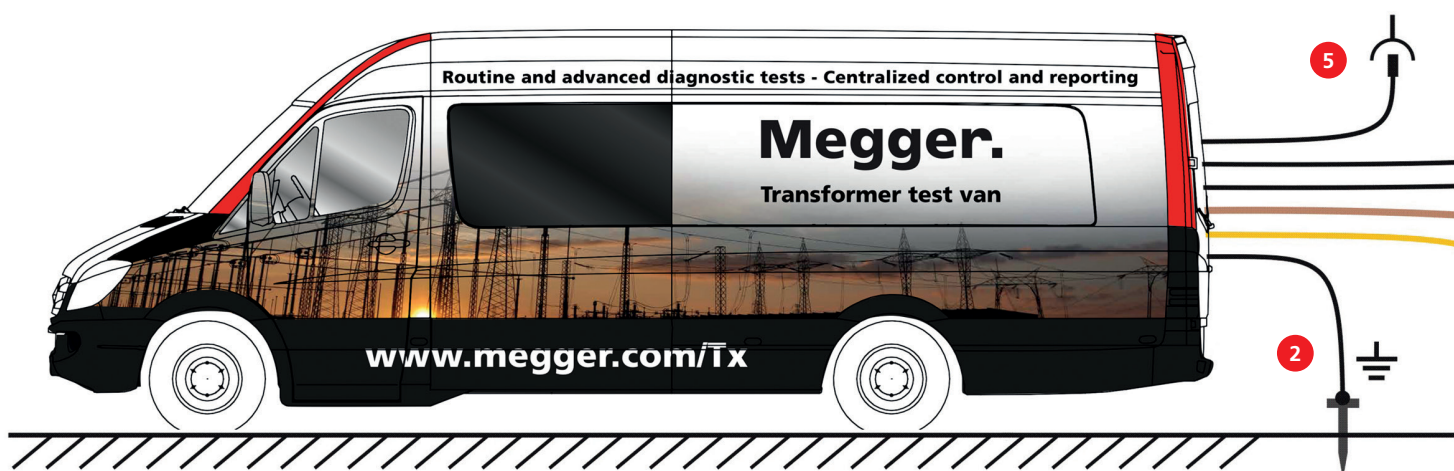

Figure 1

A dedicated, integrated test van can easily accommodate all above mentioned methods/instruments and facilitate organizing them in an automated workflow. At the heart of the system is a switch box capable of commutating the test leads between several measuring devices and test schemes (connection diagram in figure 1).

Connection sequence

- 1 Protective earth
- 2 Step voltage reference (earth spike)
- 3 External safety box
- 4 Test leads connection
- 5 Power supply

LV test connection for MTO / TTR

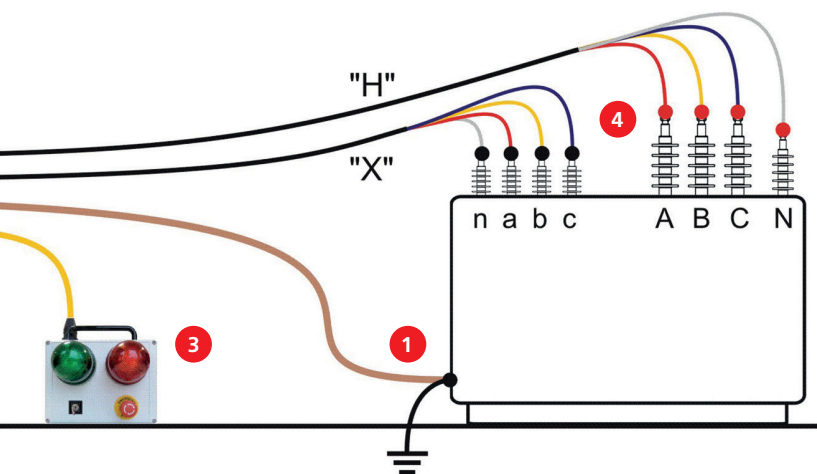

HV test connection for Delta / S1

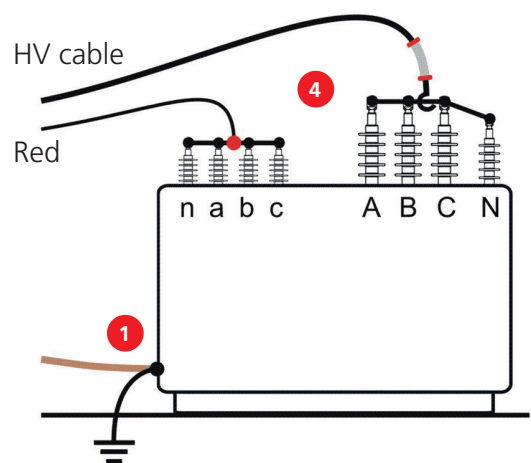

Features Transformer Test Van

Basic configuration

- A** Central computer with touch screen
- B** Control unit
- C** DC winding resistance / on-load tap changer continuity test
- D** Turns ratio and vector group verification
- E** Insulation resistance
- F** Capacitance and power factor/ dissipation factor (and exciting current) for transformer and bushings

Optional features

- Short circuit impedance
- Power losses for no-load and short circuit conditions
- Frequency response analysis
- Moisture-in-cellulose assessment with DFR technique
- Withstand tests at elevated voltage up to 100 kV AC 50 Hz and 70 kV DC
- Oil dielectric strength measurements
- and more...





- 1 HV test leads (red, blue) for insulation assessment, 30 m
- 2 LV test leads for winding resistance and turns ratio (3 ph + neutral, HV & LV side), 30 m
- 3 External safety box
- 4 HV cable, 30 m
- 5 Protective earthing cable, 50 m
- 6 Mains drum and fuse box, 50 m
- 7 Switch box
- 8 Remote control of on-load tap changer, 30 m

Operation Transformer Test Van

The user is working with two sets of test leads (for HV and LV testing). When a certain set of test leads is connected to the test object, an instrument can be selected (powered on) with an auxiliary software. Later this device is controlled by a dedicated database platform (PowerDB). Upon completion of each measurement, results are automatically transferred into a test report. PowerDB allows remote accessing, reporting and comparing the data with previous tests and eventually establishing a trend of the transformer condition over time.

Multiple field tests have proven that the measurement accuracy stays in line with single instrument's specifications. The automated selection of instruments and switching through all necessary test arrangements lead to a substantial time saving, and also help prevent accidents.

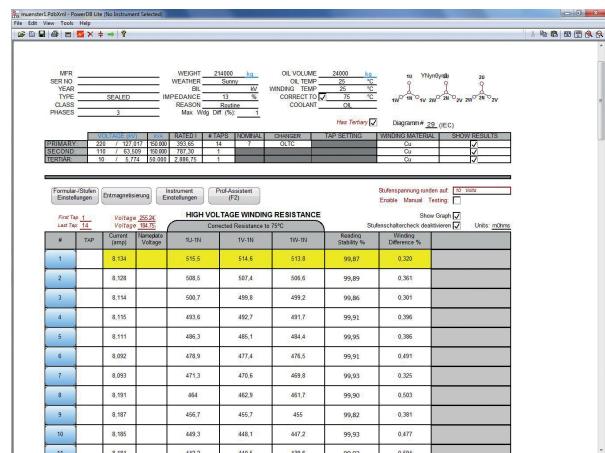

The safety concept

An essential part of the transformer test van is the safety system, which monitors all safety-relevant parameters.

The following systems are monitored:

- Step voltage: Earth to vehicle chassis
- Fast ramp voltages
- Rear door switch
- Safety-key switch
- Internal / external emergency stop
- Interlock button



Safety equipment in accordance with BGI 891 and VDE 0104



Technical parameter	Value
Power supply	100-240 V, 50-60 Hz, or three phase (optional)
Built-in power generator (optional)	TravelPower 5 kVA and higher
Test leads	30 m (optionally motorized)
Insulation testing (IR, DAR, PI, DD, SV)	
Test voltage, DC	up to 5, 10 or 15 kV
Range of measurement	100 kOhm... 15 TOhm
Charging current	2 mA, 6 mA (short circuit)
Noise immunity	8 mA
Capacitance and dissipation factor (tan δ)	
Test voltage, AC	0-12 kV
Test current (at 12 kV)	300 mA (4 minutes), 100 mA (continuous)
Test frequency range	45-70 Hz (12 kV), 15-400 Hz (4 kV), 1-500 Hz (250 V)
Measurement range of dielectric losses tan δ and capacitance	0-100 (0-10,000%), (max. resolution 0.001%) 0 -100 μ F, (max. resolution 0.01 pF)
Individual temperature correction of tan δ results	from 5°C to 50°C insulation test temperature to 20 °C reference
Noise immunity	Electrostatic 15 mA, Electromagnetic 500 μ T, at 50 Hz
Winding resistance and OLTC	
Core de-magnetisation	automatic
Test current	up to 10 A (optional up to 50 A)
Measurement range	1 μ Ohm – 2 kOhm
Accuracy	+/- 0,25%
Turns ratio and vector group	
Excitation voltage	up to 80 V
Ratio measurement range	0,8 – 45000
Phase deviation	+/-90°
Accuracy	+/-0,1%... +/- 0,3%
No-load and short-circuit loss power (optional)	
3 phase power multimeter	0-650 V, 0-100 A, 10-1000 Hz, 0-100 kW
3 phase current regulating auto transformer	up to 16 A
Voltage withstand testing (optional)	
AC 50 Hz test voltage	0... 100 kV
DC test voltage	0...70 kV
Load capacitance	0,01-1,9 nF
Leakage current measurement	up to 100 mA
Max. power consumption	20 kVA
Frequency Response Analysis (optional)	
Moisture in cellulose assessment (optional)	
Oil dielectric strength test set (optional)	up to 100 kV
Control & data acquisition & reporting	PowerDB, LabTransControl
Basic operating system	WIN 7
Interface	RS 232, USB, Ethernet
Uninterruptable power supply for industrial PC	7 min

GERMANY

Megger · Dr.-Herbert-lann-Str. 6 · D-96148 Baunach
Tel. +49 (0) 95 44 - 680 · Fax +49 (0) 95 44 - 22 73
team.international@megger.com · www.megger.com

Megger^R